

RF-MOVE Surfaces

Generation of Moving
Loads on Surfaces

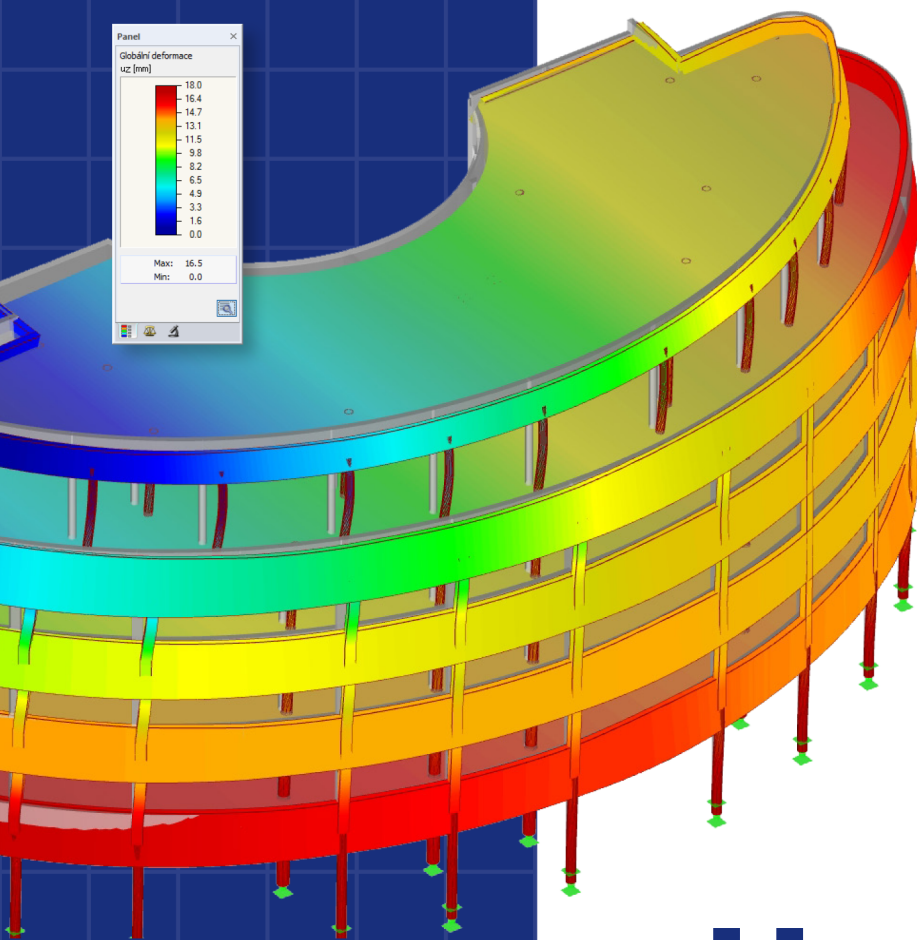

User Manual

Version

November 2017



Dlubal Software

Short Overview

1	Introduction	4
2	Input Data	7
3	Generation	21
4	Results	22
5	General Functions	25
6	Example	27
A	Literature	36



Dlubal Software GmbH
Am Zellweg 2
93464 Tiefenbach
Germany

Telephone: +49 9673 9203-0
Fax: +49 9673 9203-51
E-mail: info@dlubal.com

Dlubal Software, Inc.
The Graham Building
30 South 15th Street
15th Floor
Philadelphia, PA 19102
USA

Phone: +1 267 702-2815
E-mail: info@dlubal.com

All rights, including those of translations, are reserved. No portion of this book may be reproduced - mechanically, electronically, or by any other means, including photocopying - without written permission of Dlubal Software.

i Using the Manual

The program description is organized in chapters which follow the order and structure of the input and result tables. The chapters present the individual tables column by column. They help to better understand the functioning of the add-on module. General functions are described in the manuals of the main program RFEM or RSTAB.

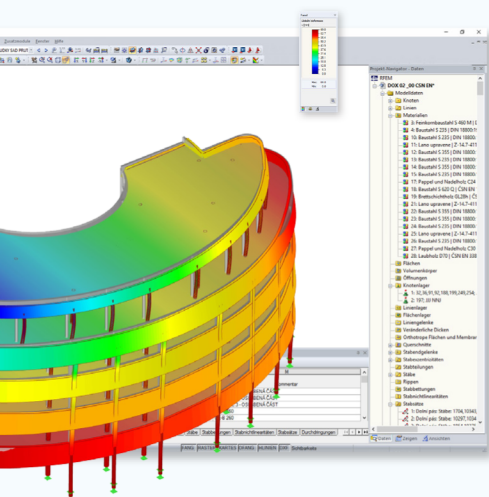

Hint

The text of the manual shows the described buttons in square brackets, for example [OK]. In addition, they are pictured on the left. Expressions appearing in dialog boxes, tables, and menus are set in *italics* to clarify the explanation. You can also use the search function for the [Knowledge Base](#) and [FAQs](#) to find a solution in the posts about add-on modules.



Topicality

The high quality standards placed on the software are guaranteed by a continuous development of the program versions. This may result in differences between program description and the current software version you are using. Thank you for your understanding that no claims can be derived from the figures and descriptions. We always try to adapt the documentation to the current state of the software.

Table of Contents

1	Introduction	4
1.1	Add-on Module RF-MOVE Surfaces	4
1.2	Using the Manual	5
1.3	Opening RF-MOVE Surfaces	5
2	Input Data	7
2.1	General Data	7
2.2	Sets of Lines	9
2.3	Moving Loads	12
2.4	Sets of Movements	18
3	Generation	21
4	Results	22
4.1	Checking the Results	22
4.2	Documentation	24
5	General Functions	25
5.1	Units and Decimal Places	25
5.2	Data Export	26
6	Example	27
6.1	System and Loads	27
6.2	Input in RF-MOVE Surfaces	27
6.2.1	General Data	27
6.2.2	Sets of Lines	28
6.2.3	Moving Loads	29
6.2.4	Sets of Movements	32
6.2.5	Generation	32
6.3	Results in RFEM	33
7	Literature	36

1 Introduction



1.1

Add-on Module RF-MOVE Surfaces

The RFEM add-on module RF-MOVE Surfaces makes it possible to easily create load cases for loads moving over surfaces. These loads can be relevant in different fields, for example, vehicle loads on bridge constructions. Based on the moving load's load positions, RFEM generates separate load cases for RFEM. Optionally, an enveloping result combination of all load positions is created.

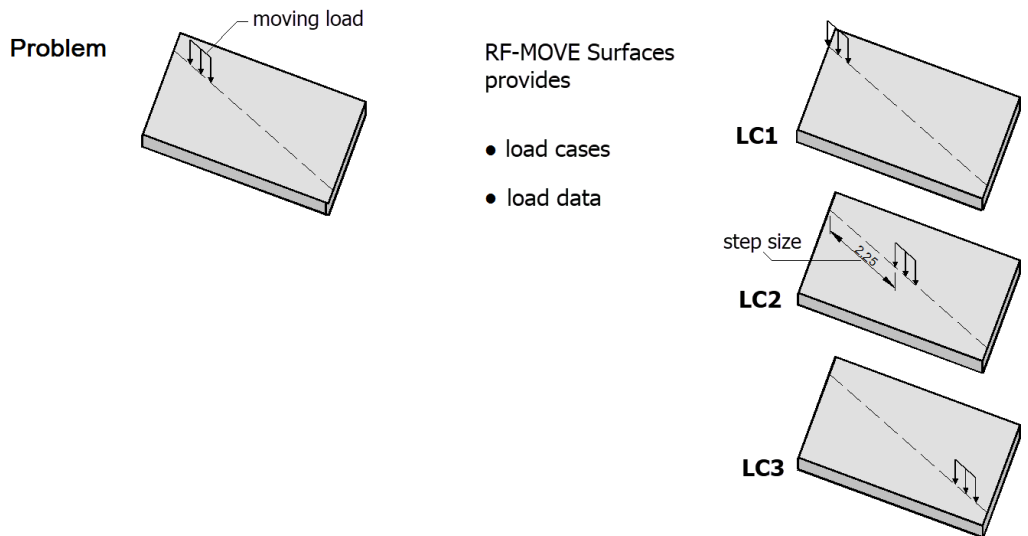

Figure 1.1 Load positions of a moving load

In order to generate the load cases, you only need to define the load parameters (such as type of load, distance between load positions) and the moving distance. A library with load models for vehicle loads helps you to define the loading. Individual load schemes can be stored in a user library. The add-on module also allows for considering influence lines and surfaces from RF-INFLUENCE.

RF-MOVE Surfaces includes useful control parameters for generating load cases. The lanes' single or area loads can be arranged parallel, eccentrically, or with off-set. Moreover, they can be limited by bumpers. An extensive database offers access to various load models according to EN 1991-2 [1] [D](#).

Normally, the load cases of moving loads are created as new cases for RFEM. Alternatively, they can also be added to existing moving load cases.

We hope you will enjoy working with RF-MOVE Surfaces.

Your Dlubal Software team

1.2

Using the Manual

Topics like installation, graphical user interface, results evaluation, and printout are described in detail in the manual of the main program RFEM. The present manual focuses on typical features of the add-on module RF-MOVE Surfaces.



The descriptions in this manual follow the sequence and structure of the module's input windows. The text of the manual shows the described **buttons** in square brackets, for example [Library]. At the same time, they are pictured on the left. Expressions appearing in dialog boxes, windows, and menus are set in *italics* to clarify the explanation.

As usual, a full-text search is possible in the PDF manual with [Ctrl] + [F]. You can also go to our [Knowledge Base](#) or the [FAQs](#) available on our website.

1.3

Opening RF-MOVE Surfaces

RFEM provides the following options to start the add-on module RF-MOVE Surfaces.

Menu

To open the add-on module on the RFEM menu, select

Add-on Modules → **Others** → **RF-MOVE Surfaces**.

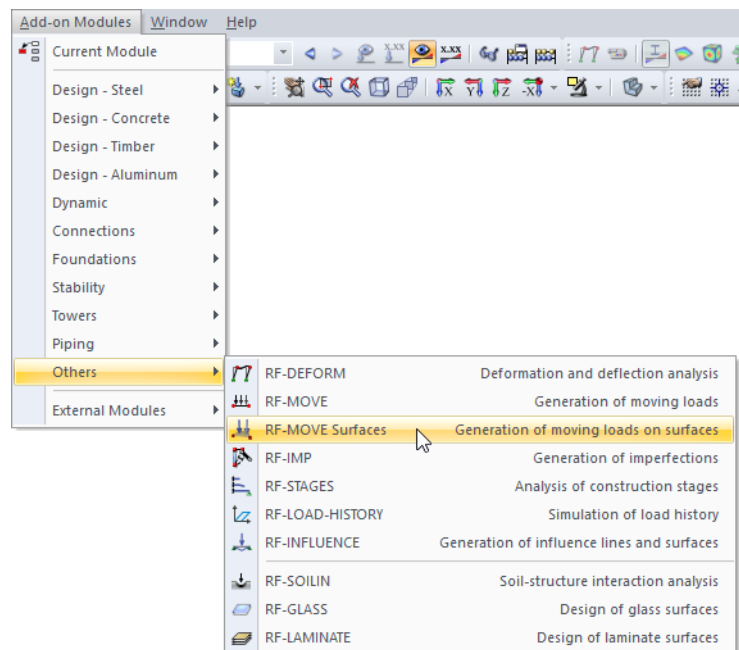

Figure 1.2 Menu Add-on Modules → Others → RF-MOVE Surfaces

Navigator

To start the add-on module in the *Data* navigator, select

Add-on Modules → **RF-MOVE Surfaces**.

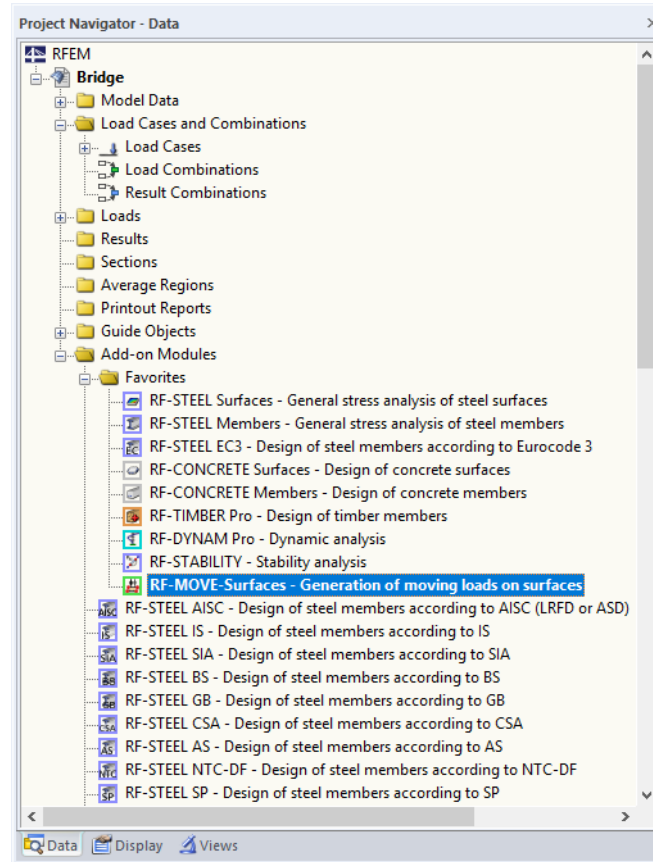

Figure 1.3 Data navigator: Add-on Modules → RF-MOVE Surfaces

2 Input Data



When you start the add-on module, a new window appears. In this window, a navigator is displayed on the left, managing the four module windows.



To select a window, click the corresponding entry in the navigator. To set the previous or next window, use the buttons shown on the left. You can also use the function keys to select the next [F2] or previous [F3] window.



To save the entered data, click [OK]. Thus, you exit RF-MOVE Surfaces and return to the main program. Click [Cancel] to exit the add-on module without saving the data.

2.1

General Data

In the 1.1 *General Data* window, you can define the relevant surfaces as well as important parameters for the generation of load cases.

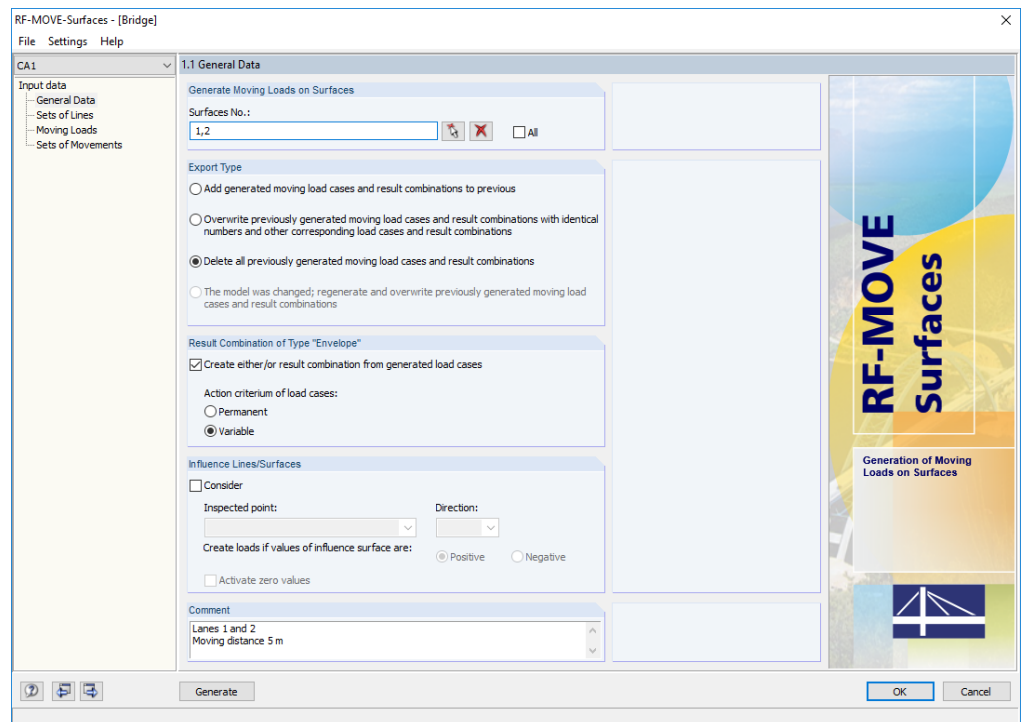

Figure 2.1 Module window 1.1 *General Data*

Generate Moving Loads on Surfaces

In this input field, you can manually enter the numbers of the *Surfaces* receiving moving loads. By selecting the *All* check box you can set all surfaces of the model.



Use the [Select] button to select the surfaces graphically in the RFEM work window. Use the [Delete] button to clear the list of preset surface numbers.

Export Type

In this window section, you can define the rules how the generated load cases for moving loads are transferred to RFEM.

Add load cases to the existing ones

The load cases from RF-MOVE Surfaces will be added to the load cases that are already available in RFEM. It is necessary to specify in the *Start Generation with* section in the 1.4 *Sets of Movements* window a starting load case number that is higher than the last number assigned in RFEM (see chapter 2.4 [☞](#)).

Overwrite load cases with identical numbers

The data of the generated load cases will overwrite all load cases that are already available with the same numbers in RFEM. This applies not only to the load data created so far by RF-MOVE Surfaces but also to user-defined load cases with higher numbers.

Delete load cases

All load cases that have already been created by RF-MOVE Surfaces will be deleted. They will be recreated with the modified specifications and filled with generation data.

This option is preset if load data is already available in the add-on module, ensuring that loads won't be created twice by mistake.

Model was changed, regenerate and overwrite load cases

If the geometry data was changed in RFEM, the following query appears when opening the add-on module again:

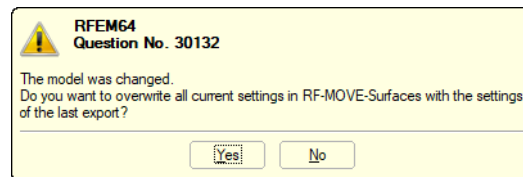

Figure 2.2 RFEM query

Irrespective of your decision, the last option in the *Export Type* section will then be enabled. Thus, it is possible to consider the modified boundary conditions for a regeneration of loads. RF-MOVE Surfaces will recreate the load cases, filling them with the adjusted data.

If you confirm the query with [Yes], the input fields in the windows 1.2 to 1.4 will be locked. The load cases must be generated again.

Result Combination of Type "Envelope"

The check box allows for generating a result combination from the load cases of the moving load. This combination contains the extreme values of the internal forces and moments, deformations, and support forces.

The load cases will be superimposed as alternatively acting (,or^c-criterion). They can be applied as *Permanent* or *Variable* acting. You can see the difference between both options, for example, if only positive internal forces are available at a position: The smallest of all positive values is shown for the permanent superposition. For the variable superposition, the value is zero.

Influence Lines/Surfaces

The check box offers the possibility to consider influence lines and surfaces determined by the add-on module RF-INFLUENCE. This way, you can reduce the amount of data because only unfavorably acting load cases will be created.

After selecting the *Consider* check box, you can choose the relevant *point* with its influence surface η in the list. In addition, you must specify the *Direction* where the unit force or moment is acting.

When considering an influence surface, the program will create only those load cases that correspond to the influence lines of the unit load on the model. You have to specify whether the positive or negative values of the influence surface are governing.

Example: For a three-span bridge with an influence surface node lying in the middle of the second span, the program creates for the positive bending moments only loads in the second span. For the negative bending moments, the program generates loads for the two external spans.

The *Activate zero values* check box makes it possible to also consider positions with influence surfaces $\eta = 0$ for the generation.

Comment

In this text box, you can enter user-defined notes describing, for example, the applied generation parameters.

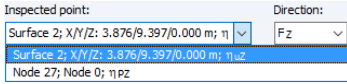

2.2

Sets of Lines

This module window manages the geometry parameters of the movable loads. It is possible to define different paths.

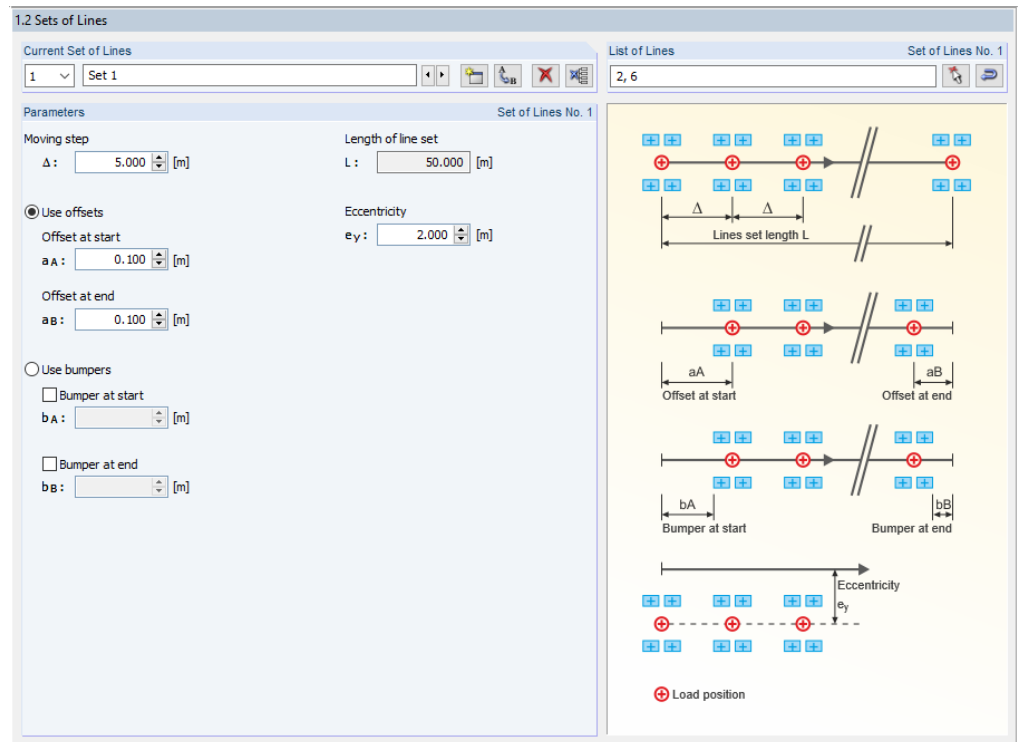

Figure 2.3 Window 1.2 Sets of Lines

Current Set of Lines

Moving loads are generated along lines. Hence, it is favorable if "guiding lines" for these loads are already available in the RFEM model.

A set of lines contains one or several lines describing the moving direction of the movable load. The number of the first set of lines is preset. The description *Set 1* can be overwritten manually.



If loads are moving parallel or with offset on surfaces, you should create another set of lines with the [New] button. Thus, an individual control of moving loads is possible in a set of movements (see [chapter 2.4](#)).

The buttons in this window section have the following functions:

Button	Function
	Goes to previous or next set of lines
	Creates a new set of lines
	Allows for renumbering current set of lines
	Deletes current set of lines
	Deletes all sets of lines without any warning

Table 2.1 Buttons for managing sets of lines

List of Lines/Set of Lines No.

In the input field, you can enter the numbers of the lines representing "guiding lines" for the moving load.



The order of the numbers specifies the moving direction.

Use the button to select the lines graphically in the RFEM work window. Again, make sure that you click the lines in the right order: The order defines the moving direction.

Clicking the button reverses the order of the lines. Then, the moving loads will run the set of lines in the opposite direction.

The total length of the set of lines is displayed in the *Parameters* section (see below).

Parameters

This window section manages general settings for the generation of load cases.

To adjust the units of length, select on the menu *Settings* → *Units and Decimal Places* (see [chapter 5.1](#)).

Moving step

The moving step Δ controls the (equal) distances by which the loads move over the surfaces. The smaller the moving step is, the more load cases are created.

Length of line set

The total length of lines existing in the current set of lines is displayed for information.

Use offsets

The load generation starts at the initial node of the first line in the set of lines and ends at the end node of the last line.

With the input fields *Offset at start* and *Offset at end* you can shift the starting point or end point of the moving load. The offset a_A describes the distance of the first load position to the initial node of the first line.

Only positive distances as shown in the sketch are allowed for an offset. In order to model a load entering the runway, you can define moving loads having negative x-locations (see [chapter 2.3](#)).

Eccentricity

This input field allows you to arrange loads beside the moving line. So you can use, for example, a surface's border line as a reference, defining a new line in RFEM is not necessary. Then, moving loads will move parallel to the lines of the set of lines in a distance of e_y .

The following sign rules are applied: The direction of the set of lines is specified by the start and end nodes. In viewing direction, positive e_y values arrange loads to the right of the moving line, negative ones to the left.

Use bumpers

As an alternative for *offsets* (see above) you can define bumper zones which are kept free of loads. Bumpers are relevant for crane runway beams and structural systems with lateral boundaries. Moving loads with negative x-locations, for example, will then be shifted until they do not extend any longer into the *Bumper at start*.

The input fields b_A and b_B allow for defining load-free areas for the start and end of the set of lines.

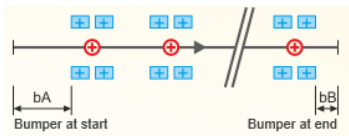
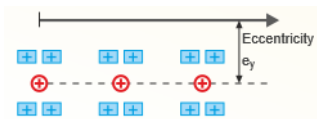
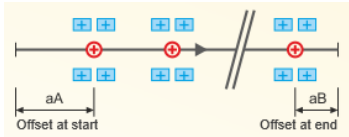

2.3

Moving Loads

This module window manages the load parameters of the movable loads. You can combine different loads in one *Load Model* moving as a "load block" over the surface.

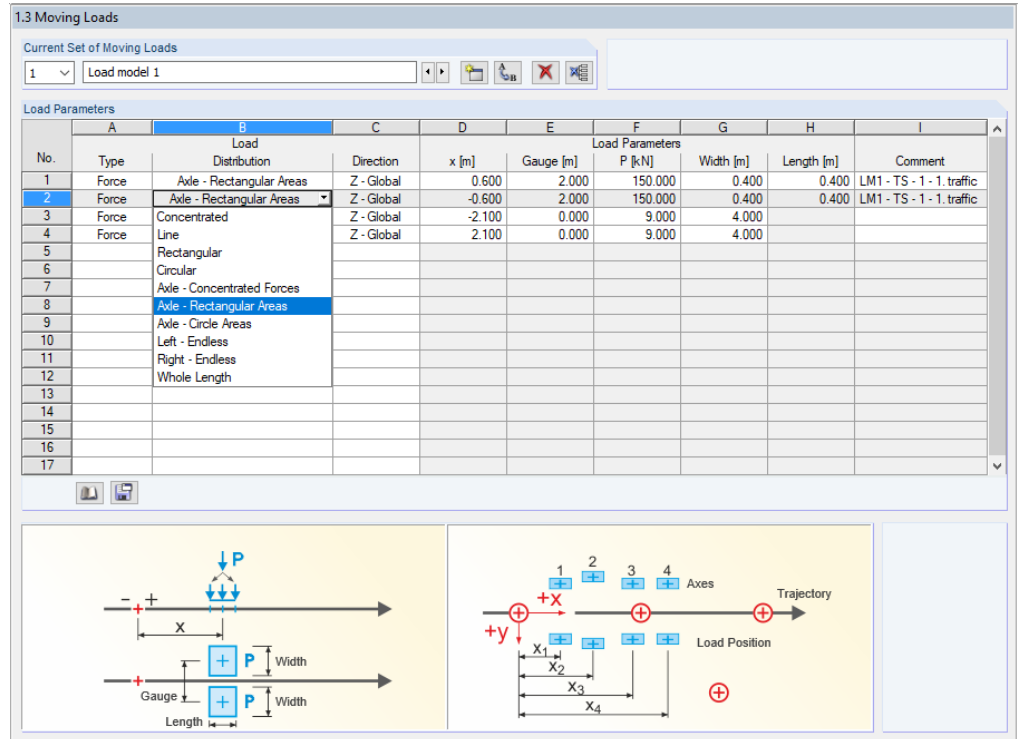

Figure 2.4 Window 1.3 Moving Loads

Current Set of Moving Loads

A set of moving loads includes one or several loads describing the moving load by forces and moments. The number of the first set of moving loads is preset. You can overwrite the description *Load model 1* manually.



If moving loads on surfaces are running parallel or with an offset, another set of moving loads should be created with the [New] button. Thus, an individual control of moving loads within one set of movements is possible (see [chapter 2.4](#)).

The buttons have the following functions:

Button	Function
	Goes to next or previous set of moving loads
	Creates a set of moving loads
	Allows for renumbering a set of moving loads
	Deletes current set of moving loads
	Deletes all sets of moving loads without any warning

Table 2.2 Buttons for managing sets of moving loads

Load Parameters

The column titles are synchronized to the selected load type and distribution.

Type

A load can be defined as Force or Moment. You can access the list with the  button or the function key [F7].



Load Distribution

The list offers different options to represent the load's effect. The selected load is shown symbolically in the graphic below the table column.

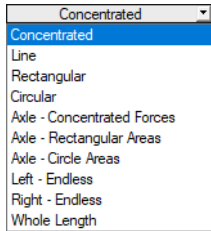

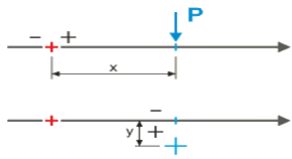
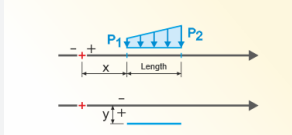
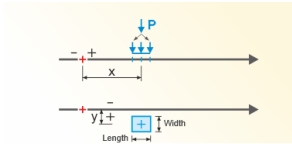
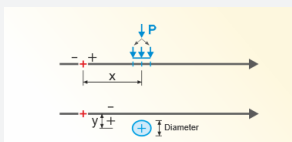
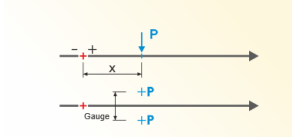
Load Distribution	Load Symbol	Description
Concentrated		Single force, single moment In addition to the load magnitude, enter the load's distances <i>x</i> along and <i>y</i> at right angle to the fixed point of the load position.
Line		Uniformly distributed load, trapezoidal load Enter the forces <i>P1</i> and <i>P2</i> , the distances <i>x</i> and <i>y</i> as well as the <i>Length</i> of the line load.
Rectangular		Areal block load In addition to the distances <i>x</i> and <i>y</i> , define the load magnitude <i>P</i> . It is converted into an area load acting on the <i>Width</i> and <i>Length</i> to be specified.
Circular		Areal round load In addition to the distances <i>x</i> and <i>y</i> , define the load magnitude <i>P</i> . It is converted into a circular area load acting on the <i>Diameter</i> to be specified.
Axle - Concentrated Forces		Single load pair Load <i>P</i> is distributed on two single loads in a distance of the <i>Gauge</i> . Enter also the distance <i>x</i> to the fixed point of the load position.



<p>Axle - Rectangular Areas</p>		<p>Block load pair The load P is distributed on two area loads in a distance of the Gauge. They each act on the Width and Length to be specified (e.g. wheel contact area).</p>
<p>Axle - Circle Areas</p>		<p>Round load pair The load P is distributed on two area loads in a distance of the Gauge. They each act on a circular area with the Diameter to be specified.</p>
<p>Left - Endless</p>		<p>Uniformly distributed load At each load position, a constant load is applied which is effective to the point where the set of lines starts. In addition to the load magnitude, enter the Width and the distance of the right load edge to the load step's fixed point.</p>
<p>Right - Endless</p>		<p>Uniformly distributed load At each load position, a constant load is applied which is effective to the point where the set of lines ends. In this case, enter the distance of the left load edge to the fixed point.</p>
<p>Whole Length</p>		<p>Uniformly distributed load A constant load acts on the total length of the set of lines. In addition to the load magnitude, enter the Width of the load. The load can be shifted, if necessary, in the distance y at right angle to the moving line.</p>

Table 2.3 Load distributions

Direction

The effect of loads can be defined *Local* in direction of the surface axes, or *Global* in direction of the axes X, Y and Z. You can access the list with the  button or the function key [F7].

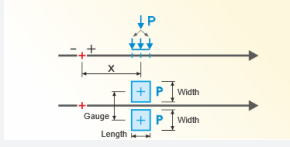
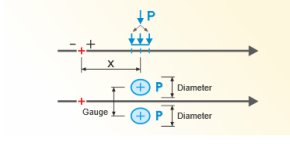
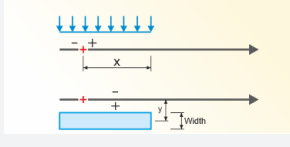
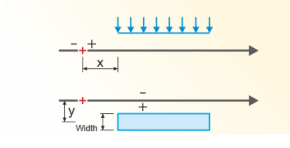
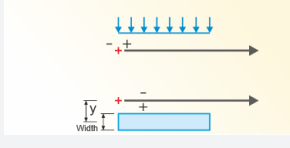
- Z - Global
- x - Local
- y - Local
- z - Local
- X - Global
- Y - Global
- Z - Global

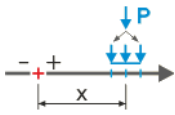
**x**

The location x describes the distance of the load to the load step's fixed point along the moving line. This point is symbolized by a red cross in the sketch.

A positive value moves the loads in the viewing direction of the set of lines. If x is negative, the load is placed before the center of the load step. This way, it is possible to model tandem axle loads entering the runway of surfaces.

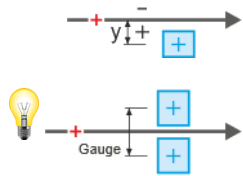
y or Gauge

This column allows you to place loads alongside the moving line. A positive y -value arranges the load in viewing direction to the right of the moving line, a negative value to the left.

Here, loads can be individually shifted at right angle to the moving line. By contrast, the *Eccentricity* in window 1.2 *Sets of Lines* shifts all loads.

If axle loads are set, table column E gets the title *Gauge*. Then, the value describes the load pair's centroidal distance according to the sketch.

P or M

In this column, you can enter the magnitudes of the force P or the moment M .

For a line load you have to enter the magnitude of the load $P1$ at the line start. The load value $P2$ at the line end can then be defined in the next column. If both values differ from each other, a trapezoidal load is applied.

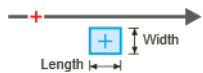
Width

For rectangular loads you have to define the load width according to the sketch. It represents the dimension of the load contact patch at right angle to the moving direction.

If an Endless load is applied, you have to specify the width of the lane on which the uniformly distributed load is acting.

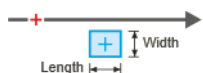
Length

In this column, you have to specify the length of the load contact patch in the direction of the moving direction, respectively the length of the line load.

The geometric conditions are taken into account when using offsets or bumpers (see [chapter 2.2](#)): The areas only get proportional loads from the contact patches.

Comment

This input field allows for a user-defined description of load parameters.

Library

Combining movable loads usually involves a lot of effort. But many load models are stored in a database that you can access with the [Library] button.

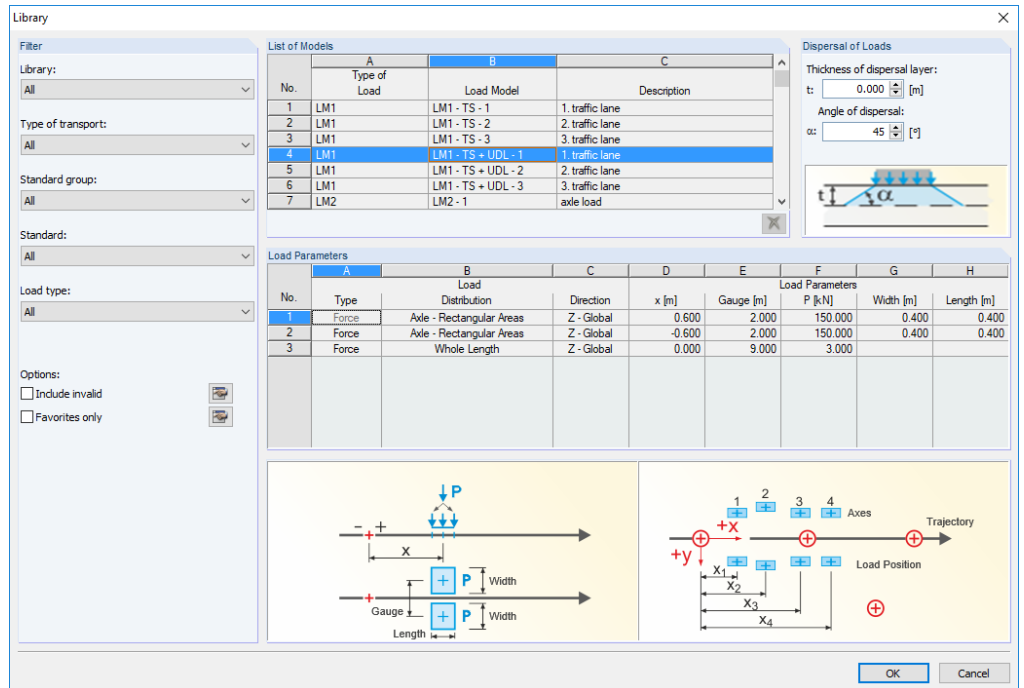
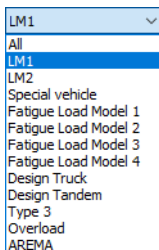

Figure 2.5 Library with load models

Filter

Use the list in this window section to filter the load models by different criteria.



List of Models

In the *Load type* list, you can find sets of moving loads described in bridge construction standards [1]. When activating a row in the table, the data record of the respective load model is shown in the *Load Parameters* section below.

The list of load models contains axle and surface loads representing the effects from truck transport and car traffic. It is being constantly expanded and adjusted to the updated standards.

Dispersal of Loads

If a *dispersal layer* is applied, you can specify its thickness t in the input field. By taking into account the *Angle of dispersal* α , this layer produces a distribution of the contact patch loads. The *Width* and *Length* load parameters will be adjusted accordingly in the window section below.

The thickness of the RFEM surface won't be automatically used for the load distribution.

[OK] transfers the load model to the 1.3 *Moving Loads* window. If load data is already there, the new loads will be added.

Saving sets of moving loads

In window 1.3, you can save the current set of moving loads so that it can be used in other projects. You can find the [Save] button below the *Load Parameters* table. It opens the *New Model* dialog box.



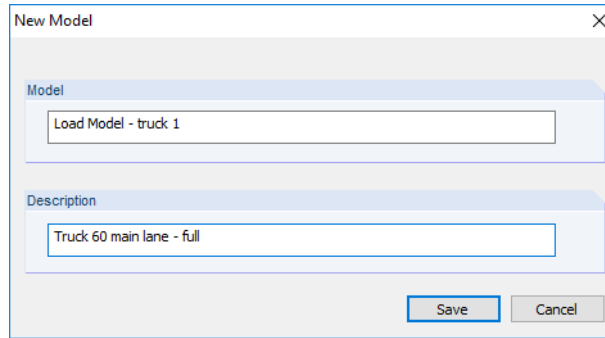
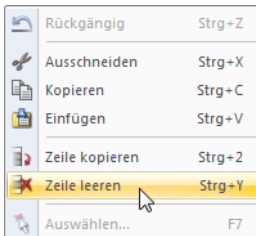

Figure 2.6 Dialog box New Model

Save



As soon as the *Model* and *Description* is entered, you can [Save] the new load model.

All user-defined load models are available for selection in the [Library]. There, they can be clearly displayed by using the *Library* filter.

Delete load row

Use the key combination [Ctrl]+[Y] to delete a table row in window 1.3. Alternatively, you can use the delete function available in the shortcut menu (for example, right-click into the input field of a selected load parameter).

2.4

Sets of Movements

This module window connects the geometry input of window 1.2 *Sets of Lines* with the load input of window 1.3 *Moving Loads*: Here, the moving load sets can be assigned to particular sets of lines. Thus, the window defines which load set is moving on which set of lines.

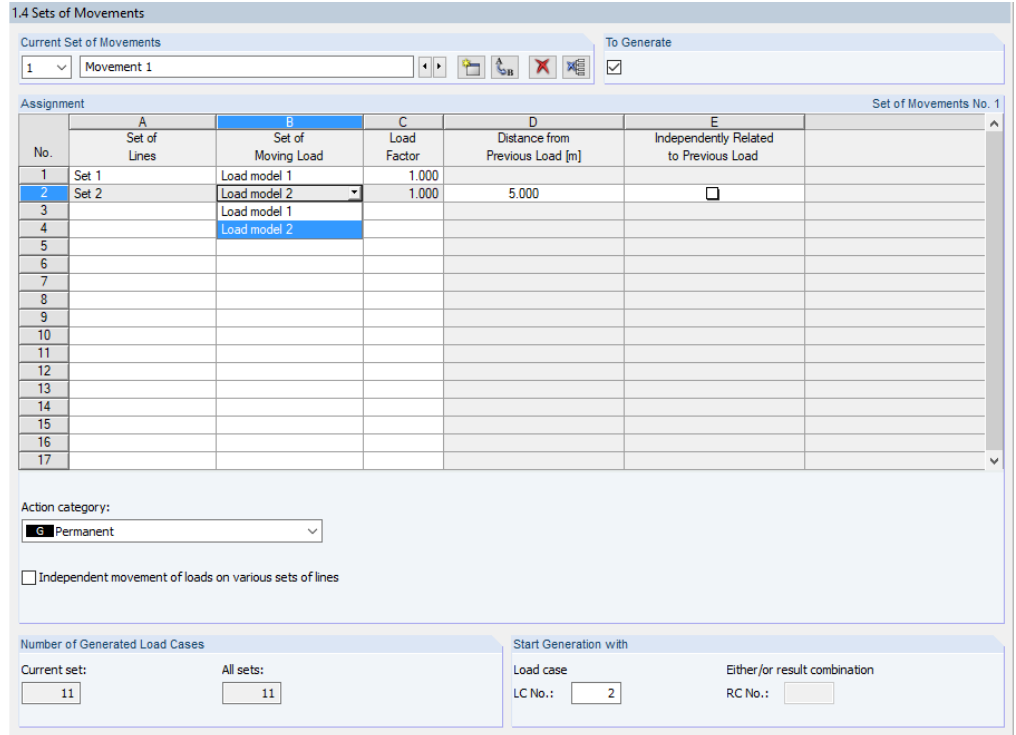

Figure 2.7 Window 1.4 Sets of Movements

Current Set of Movements

A set of movements includes one or several combinations of sets of lines with moving loads. The number of the first set of movements is preset. The description *Movement 1* can be manually overwritten.



In the majority of cases, a single set of movements will be sufficient. If moving loads are moving completely independently of each other, you can create another set of movements with the [New] button.

The buttons have the following functions:

Button	Function
	Goes to previous or next set of movements
	Creates a new set of movements
	Allows for renumbering current set of movements
	Deletes current set of movements
	Deletes all sets of movements without any warning

Table 2.4 Buttons for managing sets of movements

To Generate

With this check box you can decide if RFEM load cases will be created from the current set of movements. It is possible to remove the check mark, for example, for test purposes.

Assignment

In the table, you can assign specific moving loads to certain sets of lines. You can enter several sets of lines (e.g. lanes) with corresponding load sets (e.g. lane loads), which represents the so-called *Set of Movements*.

Set of Lines

In the list, you can select a set of lines that has been defined in window 1.2. You can access the list with the  button or the function key [F7].

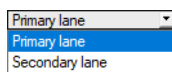
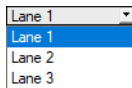

Set of Moving Load

In the second column, you can define the set of moving loads which is moving along the set of lines. The list allows for a selection among the moving load combinations defined in window 1.3.

Load Factor

The effect of the load combination can be scaled by a factor.

Distance from Previous Load

No.	A	B	C	D	E
	Set of Lines	Set of Moving Load	Load Factor	Distance from Previous Load [m]	Independently Related to Previous Load
1	Lane 1	Primary lane	1.000		
2	Lane 1	Primary lane	1.000	10.000	<input type="checkbox"/>

Figure 2.8 Defining distance to previous load

This column is accessible as soon as a set of lines is again selected for load assignment in column A. It allows for applying a combination of loads with an offset on the same set of lines. This way, load models with tandem axles, for example, can run successively over the surface.

The load distance to the fixed point of the previous load position must be specified as a positive value.

Independently Related to Previous Load

Also this column is only accessible if a set of lines appears several times in column A (see [Image 2.8](#)). The check box is not ticked by default. So the second load set is moving synchronously to the first one along the set of lines.

If this option is activated, both load sets are moving independently over the surfaces - individually as well as together. With regard to combinations, the distance defined in column D is considered as the minimum distance between the load positions.

Action category

Each load case must be assigned to an *Action* category controlling the superposition of load cases as well as partial safety and combination factors in RFEM (see RFEM manual, chapter 5.1). You can select the appropriate category in the list. It applies to all load cases that are created by RF-MOVE Surfaces.

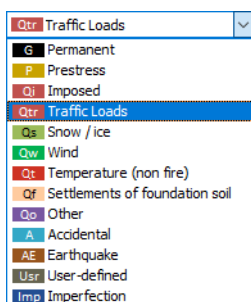

Independent movement of loads on various sets of lines

The loads are moving according to the moving step Δ defined in window 1.2 along the sets of lines. If several sets of lines ("paths") are defined in the table above, the generation starts for the starting points of each set of lines. Thus, depending on the sets of lines' arrangement and direction, loads are created which are moving, for example, parallel over the surfaces or in the opposite direction.

If the check box is ticked, the load sets will run independently over the surfaces. All constellations will be combined, which has a corresponding impact on the number of generated load cases.

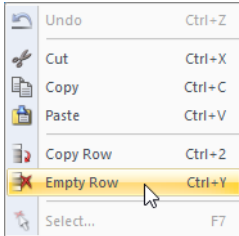

Delete load row

Use the key combination [Ctrl]+[Y] to delete a table row in window 1.4. Alternatively, you can use the delete function available in the shortcut menu (for example, right-click into selected input field).

Number of Generated Load Cases

This window section displays the number of load cases that can be expected by the selected settings. It represents a useful checking option before the generation starts.

Start Generation with

You have to specify the No. which should be given to the first generated load case. The subsequent load positions will then be numbered in ascending order.

If an *Either/or result combination* has been specified for the generation in window 1.1 (see chapter 2.1 [☞](#)), it is also possible to define the No. of the "enveloping" RC.

Start Generation with	
Load case	Either/or result combination
LC No.: <input type="text" value="20"/>	RC No.: <input type="text" value="3"/>

3 Generation



Generate

This chapter describes how the load cases and the result combination are created for RFEM.

Each module window of RF-MOVE Surfaces provides a [Generate] button. Use this button to create the load cases and the result combination for RFEM.

After a successful generation, the numbers of the new load cases and the new result combination, if applicable, are shown in a message.

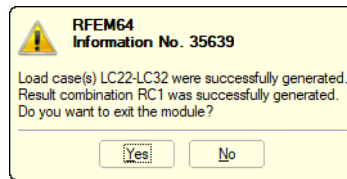

Figure 3.1 Message after generation

Now, the generation is completed.

After confirming the message with [Yes], you exit the add-on module RF-MOVE Surfaces. Then, the created load cases can be checked in the work window of RFEM (see [chapter 4.1](#)). If you click [No], you return to RF-MOVE Surfaces in order to adjust, for example, the generation settings.

It is not possible to create load cases for RF-MOVE Surfaces in the graphical user interface of RFEM.



4 Results



This chapter describes how the generated loads can be checked and adjusted, if necessary.

4.1 Checking the Results

The add-on module RF-MOVE Surfaces doesn't have any results windows. But the load cases including the generated loads can be checked in the RFEM work window.

OK

The message displayed after the generation allows you to exit RF-MOVE Surfaces and to return to RFEM (see [Image 3.1](#)). You can also use the [OK] button which is available in every module window.

The generated load cases can be displayed in RFEM in the following ways:

- Data navigator: **Load Cases and Combinations** → **Load Cases**
- Toolbar: list of load cases
- Table: [2.1 Load Cases](#)
- Menu: **Edit** → **Load Cases and Combinations** → **Load Cases**

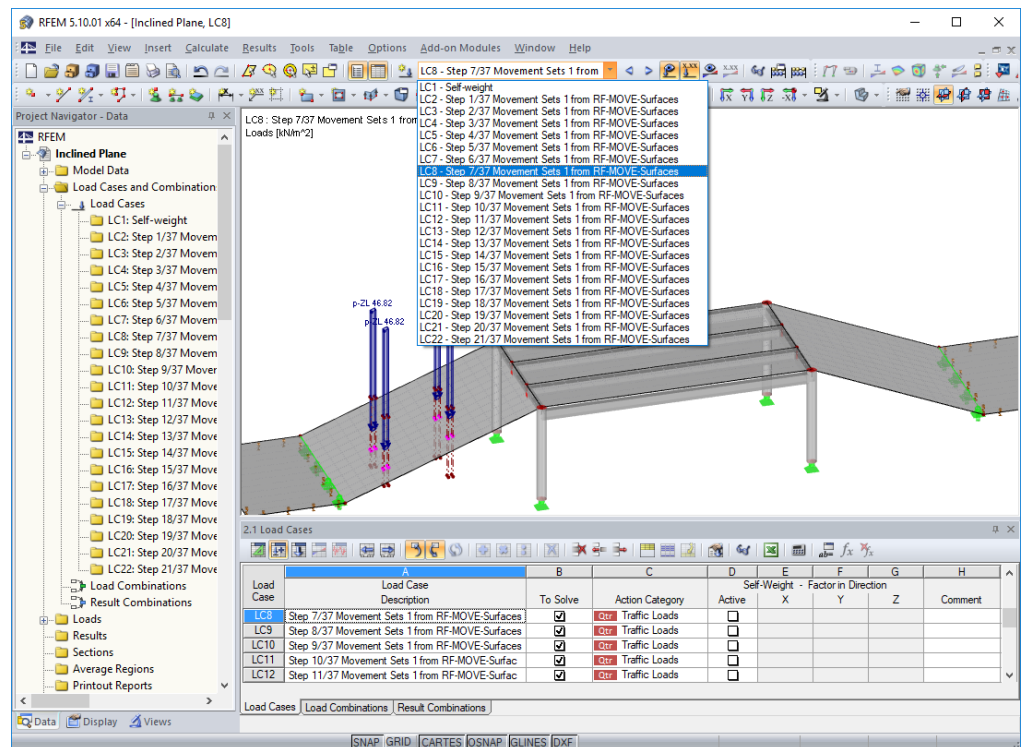

Figure 4.1 Generated load cases in navigator, load case list and table

The *Descriptions* of the load positions are automatically created, based on the load step numbers. If required, you can adjust them in the *Edit Load Cases and Combinations* dialog box (see [Image 4.2](#)).

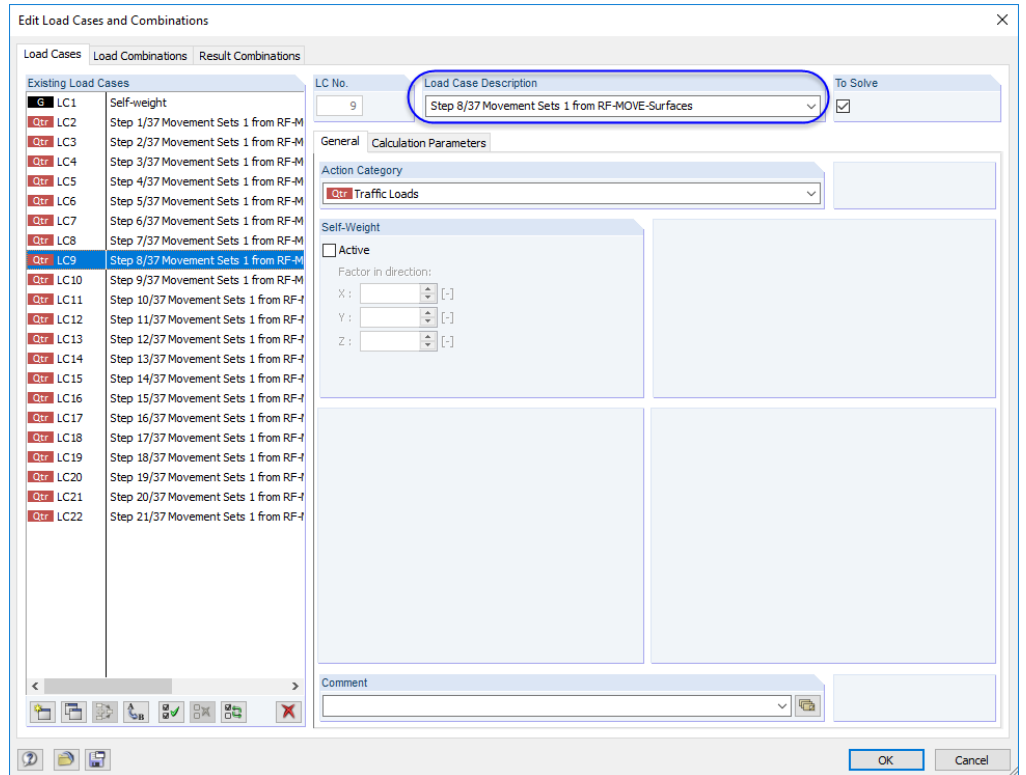

Figure 4.2 Dialog box *Edit Load Cases and Combinations*

If a result combination has been generated with RF-MOVE Surfaces, it is also listed in the *Data* navigator. The superposition parameters can be checked in the *Result Combinations* tab of the *Edit Load Cases and Combinations* dialog box.

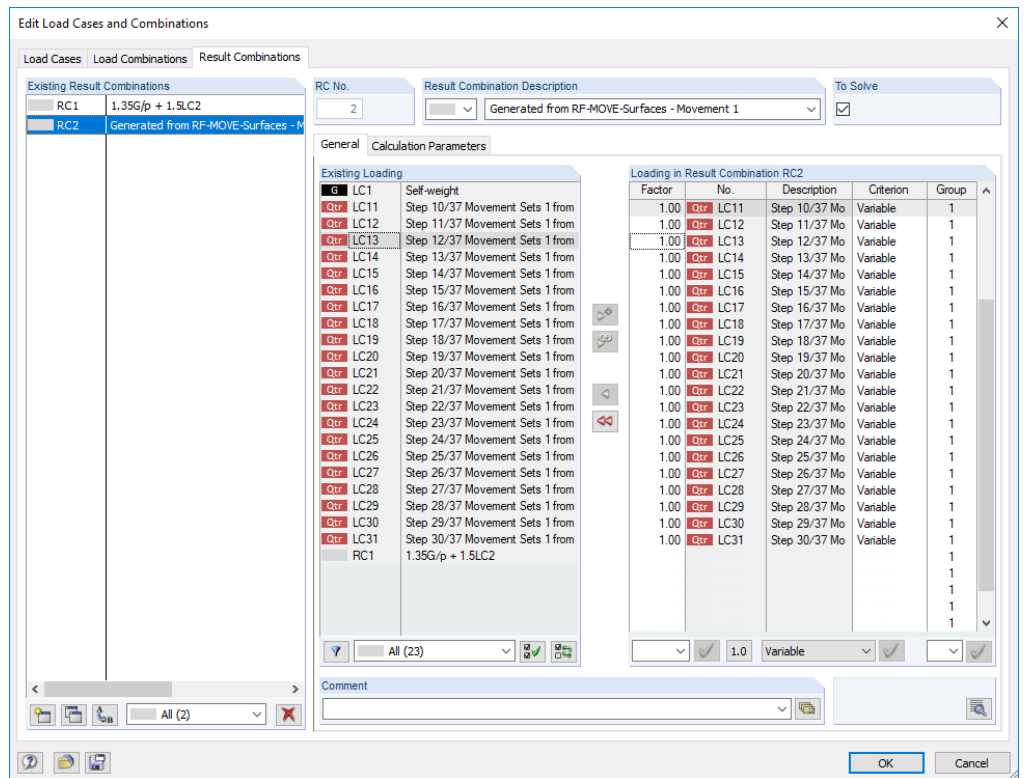

Figure 4.3 Dialog box *Edit Load Cases and Combinations*, tab *Result Combinations*

The loads that have been generated in the individual load cases can be checked as usual in the graphic, the edit dialog boxes, or in table 3. Loads. They entered the corresponding tables as free concentrated loads, free line loads, or free polygon loads.

No.	On Surfaces No.	Projection	Load Distribution	Load Direction	Load Position	Magnitude [kN/m]	Comment
					X1 [m] Y1 [m] X2 [m] Y2 [m]	p1 p2	
1	1-5	XY	Linear	ZL	-3.000 4.000 1.000 4.000	3.500 7.500	
2	1-5	XY	Linear	x	-3.000 4.000 1.000 4.000	-0.200 -0.200	
3							
4							
5							

Figure 4.4 Table 3.7 Free Line Loads with generated moving loads

No.	On Surfaces No.	Projection	Load Distribution	Load Direction	Surface base area nodes [m]	1st Corner Point	2nd Corner Point
					X1, Y1; X2, Y2; X3, Y3; ...	No. p1 [kN/m²]	No. p2 [kN/m²]
1	1-5	XY	Uniform	ZL	5.61797506541427,5.06367077907141;5.6179750	46.82	
2	1-5	XY	Uniform	ZL	5.61797506541427,3.37827826371907;5.6179750	46.82	
3	1-5	XY	Uniform	ZL	8.23969691331434,5.06367077907141;8.2396969	46.82	
4	1-5	XY	Uniform	ZL	8.23969691331434,3.37827826371907;8.2396969	46.82	
5							

Figure 4.5 Table 3.10 Free Polygon Loads with generated moving loads

4.2

Documentation

The data of the add-on module RF-MOVE Surfaces is not managed separately in the printout report. The generated load cases including loads are transferred to RFEM where they can be integrated into the documentation.

2.1.1 LOAD CASES - CALCULATION PARAMETERS

Load Case	Load Case Description	Calculation Parameters
LC11	Step 10/11 Movement Sets 1 from RF-MOVE-Surfaces	Method of analysis: Geometrically linear analysis Method for solving system of nonlinear algebraic equations: Newton-Raphson
LC12	Step 11/11 Movement Sets 1 from RF-MOVE-Surfaces	Method of analysis: Geometrically linear analysis Method for solving system of nonlinear algebraic equations: Newton-Raphson

3.10 FREE POLYGON LOADS

No.	On Surfaces No.	Project	Load Distribution	Load Direction	Symbol	Load Parameters	Unit	Load Position
						Value		X [m] Y [m] Z [m]
1	1,2	XY	Uniform	ZL	p	897.50	kN/m²	0.400 7.200 0.000
						897.50	kN/m²	0.400 6.800 0.000
						897.50	kN/m²	0.800 6.800 0.000
2	1,2	XY	Uniform	ZL	p	897.50	kN/m²	0.800 7.200 0.000
						897.50	kN/m²	0.400 5.200 0.000
						897.50	kN/m²	0.400 4.800 0.000
3	1,2	XY	Uniform	ZL	p	897.50	kN/m²	0.800 4.800 0.000
						897.50	kN/m²	0.800 4.800 0.000
						897.50	kN/m²	27.100 8.000 0.000
4	1,2	XY	Uniform	ZL	p	897.50	kN/m²	2.100 8.000 0.000
						897.50	kN/m²	50.000 4.000 0.000
						897.50	kN/m²	27.100 4.000 0.000
5	1,2	XY	Uniform	ZL	p	897.50	kN/m²	27.100 8.000 0.000
						897.50	kN/m²	27.100 4.000 0.000
						825.00	kN/m²	0.400 3.200 0.000

Figure 4.6 Printout report

5 General Functions



This chapter describes useful menu functions as well as export options for the designs.

5.1

Units and Decimal Places

The units and decimal places are managed together for RFEM and the add-on modules. You can access the dialog box for adjusting the units by selecting on the RF-MOVE Surfaces menu

Settings → **Units and Decimal Places**.

The dialog box known from RFEM appears. RF-MOVE Surfaces is preset in the *Program / Module* list.

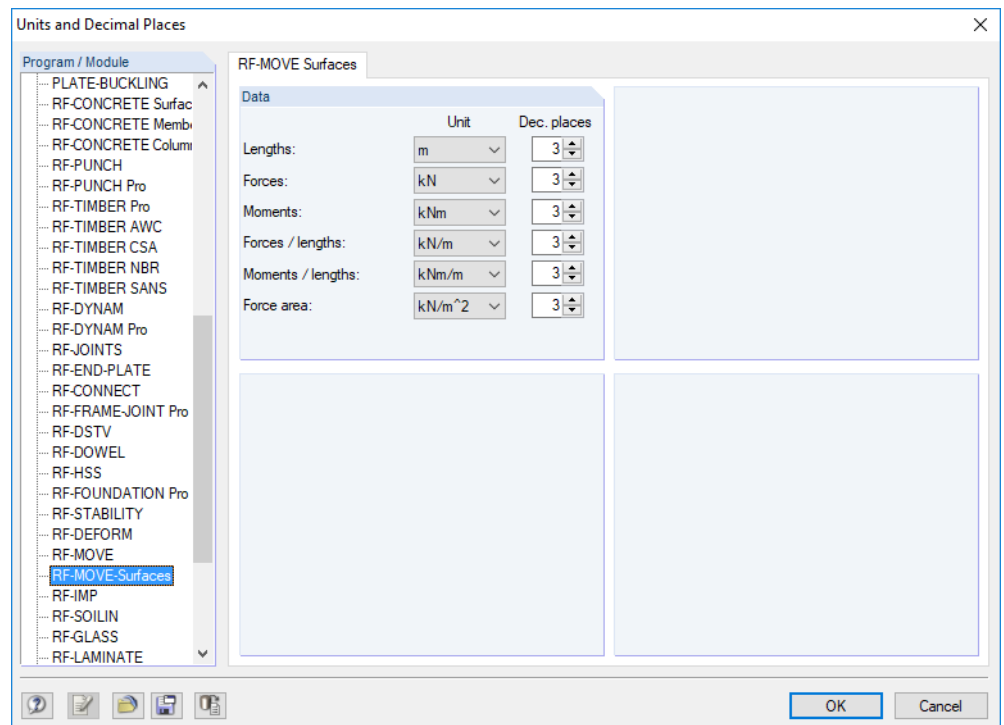

Figure 5.1 Dialog box *Units and Decimal Places*



The settings can be saved in a user profile to reuse them in other models. These functions are described in chapter 11.1.3 of the RFEM manual.

5.2

Data Export

RF-MOVE Surfaces provides a function for directly exporting data to MS Excel or the CSV file format. In line with the module's concept, only the *Load Parameters* table of the 1.3 *Moving Loads* window comes into consideration for the export.

To open the export dialog box, go to the menu and select

File → **Export Tables**.

The following export dialog box opens.

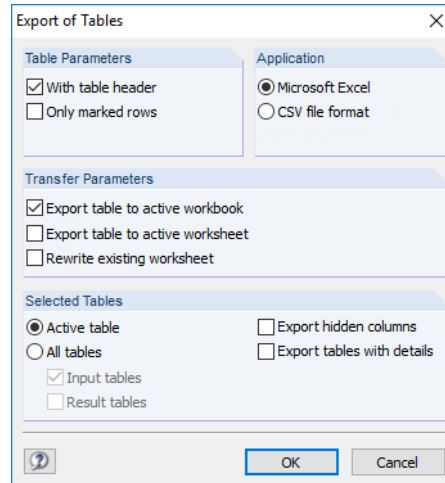

Figure 5.2 Dialog box *Export of Tables*

Click [OK] to start the data export. Excel will be started automatically, that means that you do not need to open the program first.

6 Example



6.1 System and Loads

The example describes traffic loads running on a bridge construction, illustrating the module's application possibilities.

A truck with a load of 300 kN (tandem system with double axles) is running on a deck of 50 m x 8 m. On the second lane, the load position of a tandem axle system of 200 kN is parallel applied.

Additionally, a uniform loading of 9 kN/m² is acting on lane 1, and of 2.5 kN/m² on lane 2. It must be considered in a distance of 1.5 m in front of and behind the tandem axles.

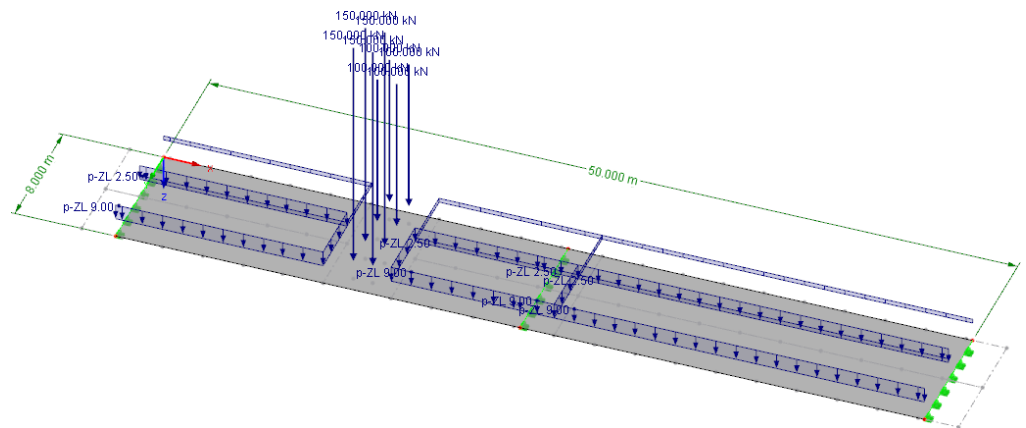

Figure 6.1 Deck with loading

6.2 Input in RF-MOVE Surfaces

The model is created in RFEM. The deck consists of two surfaces each with a length of 25 m and a width of 8 m.

6.2.1 General Data

When you open RF-MOVE Surfaces, window 1.1 *General Data* is displayed.

Tick the **All** check box in the *Generate Moving Loads on Surfaces* section.

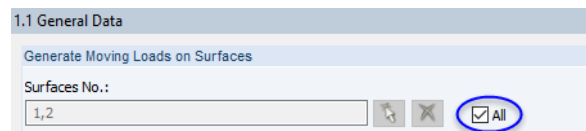

Figure 6.2 Input in window 1.1 General Data

6.2.2 Sets of Lines

In the 1.2 Sets of Lines window, we define the "moving lines" of the loads. For both lanes we define two sets of lines.

The moving step Δ must be the same in both sets of lines in order to let the loads move parallel.

Lane 1

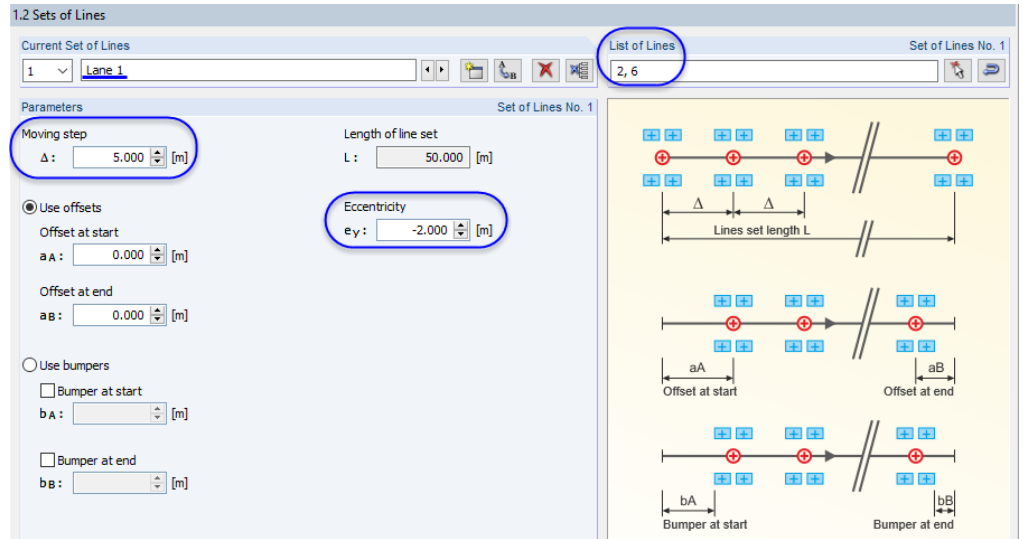

Figure 6.3 Input in window 1.2 Sets of Lines for lane 1

The description **Lane 1** makes the assignment easier later.

In the *List of Lines* section, we specify the numbers of the two longitudinal border lines serving as "guiding lines" for lane 1. With the button you can define these lines graphically. The order of numbers determines the moving direction!

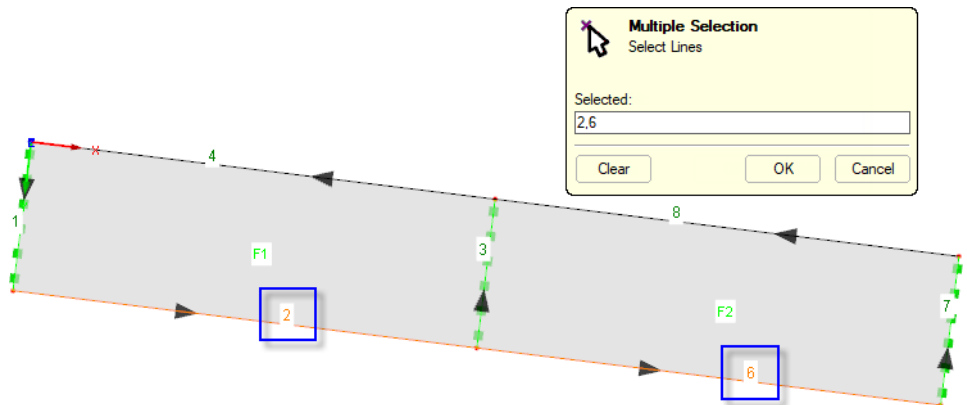

Figure 6.4 Graphical selection of lines for set of lines 1

We specify the *Moving step* Δ with **5 m**. So every 5 m a fixed point is created for the loads.

In the *Eccentricity* section, we enter a lateral distance of **-2 m** in order to shift the guiding line to the center of the lane which has a width of 4 m. In our example, you must enter the distance with a negative value because the loads are acting left in the lines' viewing direction (see image above).

Lane 2

Create a second set of lines with the [New] button. Enter **Lane 2** as the description.

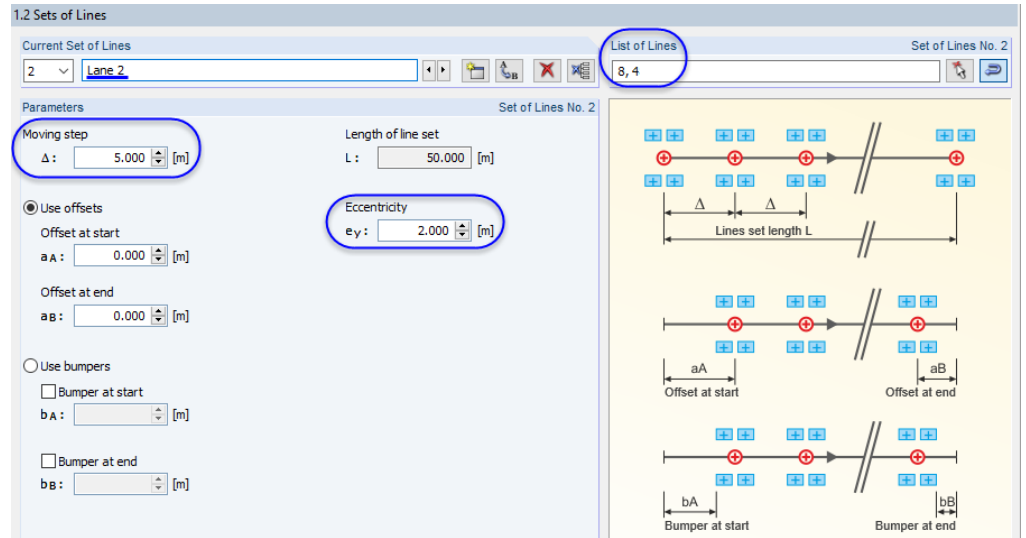

Figure 6.5 Input in window 1.2 Sets of Lines for lane 2

In the *List of Lines* section, we define the numbers of the lines lying on the opposite side of the lane. They serve as a guiding line for lane 2. Again, the order of the lines determines the moving direction.

The *Moving step* Δ is again **5 m** so that the loads in both sets of lines are moving parallel.

In the *Eccentricity* section, we enter a lateral distance of **2 m** in order to shift the guiding line to the center of the lane which has a width of 4 m. This time, the distance is a positive value because the loads are acting to the right of the set of lines (see Image 6.4 [\[4\]](#)).

6.2.3 Moving Loads

In the 1.3 *Moving Loads* window, we define the load parameters. We define two sets of moving loads for both lanes.

Lane 1

The description **Tandem axle 300 kN** makes easier the assignment later.



Figure 6.6 Description in window 1.3 Moving Loads for lane 1

We use the [Library] for load input (see following image).

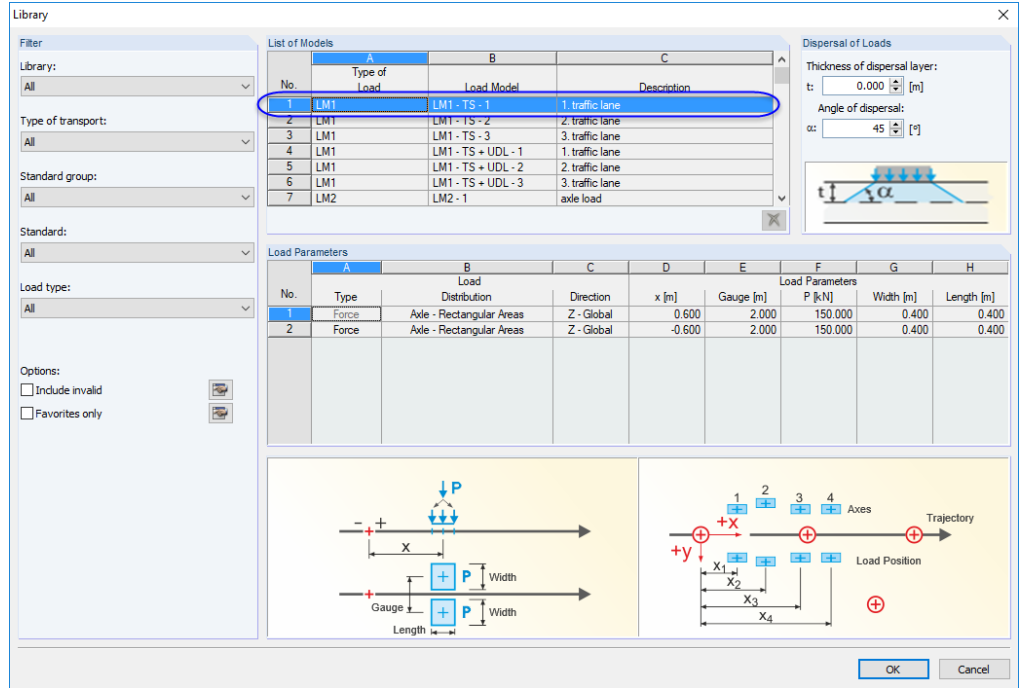

Figure 6.7 Library with load models

We select the load model **LM1 - TS - 1**. In the *Load Parameters* section, the load magnitudes (twice 150 kN), the contact patches (0.40 m x 0.40 m) and the gauge (2 m) are shown. The distance between the load positions x is 1.2 m. The first axle load is applied with a forward shift of 60 cm from the load fixed point in the direction of the moving line, the second axle load is set with a shift of 60 cm backwards. Thus, at the starting point of the moving line, the first axle is already on the deck whereas the second axle has not yet entered the runway.

Click [OK] to transfer the load model to the 1.3 *Moving Loads* window.

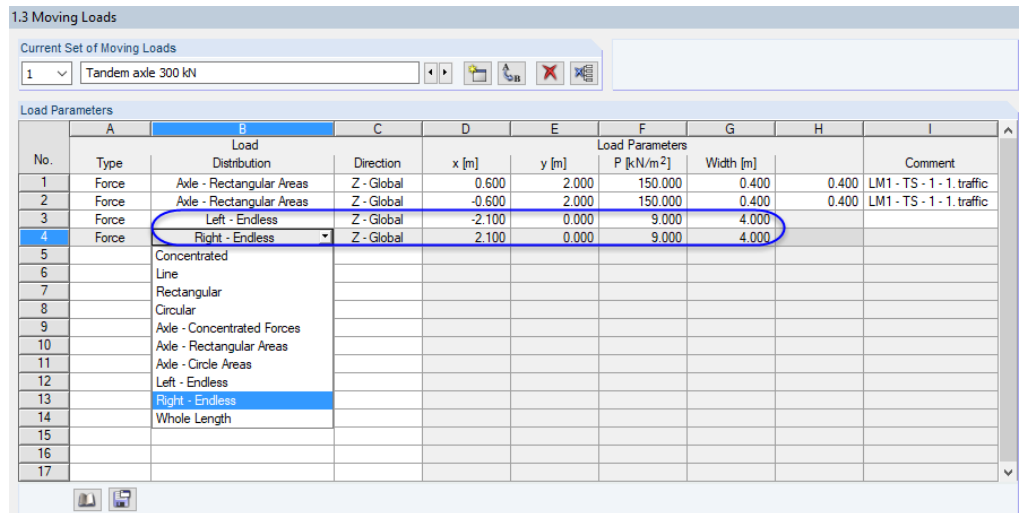

Figure 6.8 Input in window 1.3 Moving Loads for lane 1

We define the uniform loading of **9 kN/m²** in front of and behind the tandem axles by the load distributions **Left - Endless** and **Right - Endless** entered in table rows 3 and 4. The width of the lane is **4 m**.

In order to consider the distance of 1.5 m in front of and behind the tandem axles, we define the location x on the left with **-2.1 m** (-0.60 m - 1.50 m) and on the right with **2.1 m** (0.60 m + 1.50 m).

Lane 2



We create a second set of moving loads with the [New] button. We enter **Tandem axle 200 kN** as a description.



Again, we use the [Library] for entering the tandem axle load. We select the load model **LM1 - TS - 2** with 100 kN wheel load each.

The screenshot shows the 'List of Models' dialog box with a table of load models. Row 2 is selected, showing 'LM1' as the Type of Load and 'LM1 - TS - 2' as the Load Model, with a description of '2. traffic lane'. To the right, the 'Dispersal of Loads' panel shows 'Thickness of dispersal layer: t: 0.000 [m]' and 'Angle of dispersal: α: 45 [°]'. Below these panels is a diagram of a load dispersal on a surface.

No.	Type of Load	Load Model	Description
1	LM1	LM1 - TS - 1	1. traffic lane
2	LM1	LM1 - TS - 2	2. traffic lane
3	LM1	LM1 - TS - 3	3. traffic lane
4	LM1	LM1 - TS + UDL - 1	1. traffic lane
5	LM1	LM1 - TS + UDL - 2	2. traffic lane
6	LM1	LM1 - TS + UDL - 3	3. traffic lane
7	LM2	LM2 - 1	axle load

No.	Type	Load Distribution	Direction	x [m]	Gauge [m]	Load Parameters P [kN]	Width [m]	Length [m]
1	Force	Axle - Rectangular Areas	Z - Global	0.600	2.000	100.000	0.400	0.400
2	Force	Axle - Rectangular Areas	Z - Global	-0.600	2.000	100.000	0.400	0.400

Figure 6.9 Selection of load model

Click [OK] to transfer the load model to the 1.3 Moving Loads window.

The screenshot shows the '1.3 Moving Loads' window. The 'Current Set of Moving Loads' is set to '2 Tandem axle 200 kN'. Below is a table of load parameters for lane 2.

No.	Type	Load Distribution	Direction	x [m]	y [m]	Load Parameters P [kN/m ²]	Width [m]	Comment
1	Force	Axle - Rectangular Areas	Z - Global	0.600	2.000	100.000	0.400	LM1 - TS - 2 - 2. traffic
2	Force	Axle - Rectangular Areas	Z - Global	-0.600	2.000	100.000	0.400	LM1 - TS - 2 - 2. traffic
3	Force	Left - Endless	Z - Global	-2.100	0.000	2.500	4.000	
4	Force	Right - Endless	Z - Global	2.100	0.000	2.500	4.000	
5								
6								
7								
8								
9								
10								
11								
12								
13								
14								
15								
16								
17								

Figure 6.10 Input in window 1.3 Moving Loads for lane 2

We define the uniform loading of **2.5 kN/m²** in front of and behind the tandem axles by the load distributions **Left - Endless** and **Right - Endless**.

The width of the lane is again **4 m**. And again, the distance of 1.5 m in front of and behind the tandem axles is considered by the locations x of **-2.1 m** and **2.1 m**.

6.2.4 Sets of Movements

In the 1.4 Sets of Movements window, we combine the sets of lines with the corresponding loads.

1.4 Sets of Movements

Current Set of Movements: 1 Movement 1 To Generate:

Assignment

No.	A Set of Lines	B Set of Moving Load	C Load Factor	D Distance from Previous Load [m]	E Independently Related to Previous Load
1	Lane 1	Tandem axle 300 kN	1.000		
2	Lane 2	Tandem axle 200 kN	1.000		
3	Lane 1				
4	Lane 2				
5					
6					
7					
8					
9					
10					
11					
12					
13					
14					
15					
16					
17					

Action category:

Independent movement of loads on various sets of lines

Number of Generated Load Cases

Current set: All sets:

Start Generation with

Load case LC No.: Either/or result combination RC No.:

Figure 6.11 Combining sets of lines and loads in window 1.4 Sets of Movements

We assign the **Tandem axle 300 kN** to **Lane 1** and the **Tandem axle 200 kN** to **Lane 2**. Sets of lines and sets of moving loads can be selected in the list with the button.

In the *Number of Generated Load Cases* section, we can see that eleven load cases will be created considering the specified moving step. The number of the starting load case can be defined individually in the *Start Generation with* section.

6.2.5 Generation

Generate

We click the [Generate] button to create the eleven load cases.

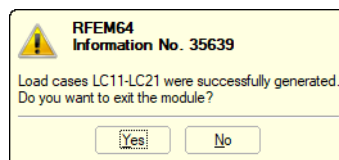

Figure 6.12 Message after generation

We confirm the query with [Yes] and exit the add-on module RF-MOVE Surfaces.

6.3

Results in RFEM

The list of load cases allows for browsing in the generated load cases and seeing the loads visualized on the model. The distance of the surface load in front of and behind the tandem system can be clearly seen.

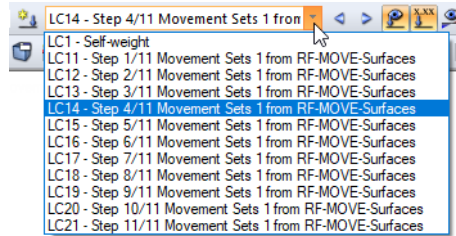

Figure 6.13 Load case list

LC14 : Step 4/11 Movement Sets 1 from RF-MOVE-Surfaces
Loads [kN/m²]

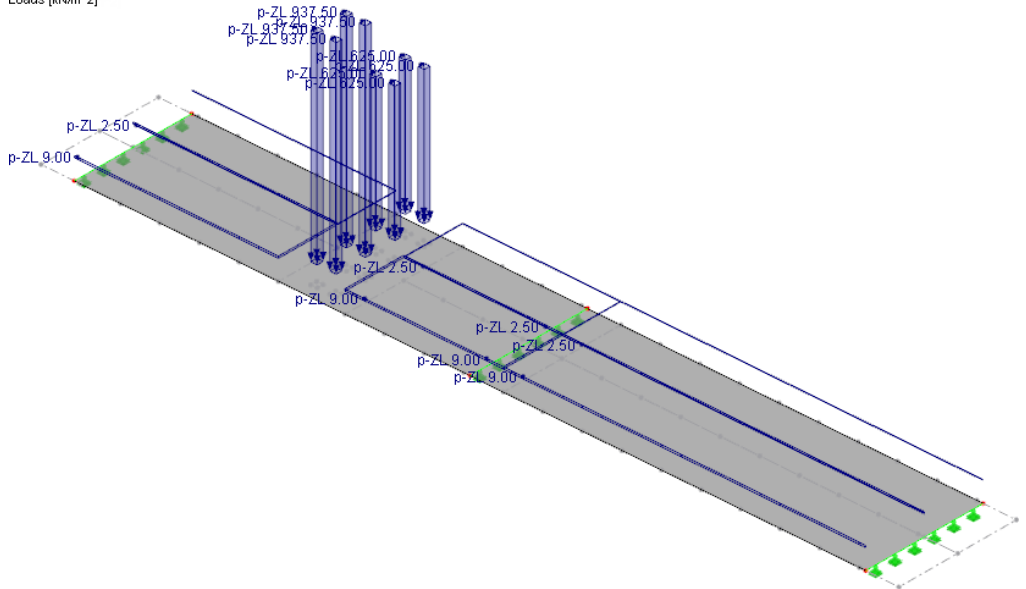

Figure 6.14 Load step 4 with tandem axle and surface loads

LC15 : Step 5/11 Movement Sets 1 from RF-MOVE-Surfaces
Loads [kN/m²]

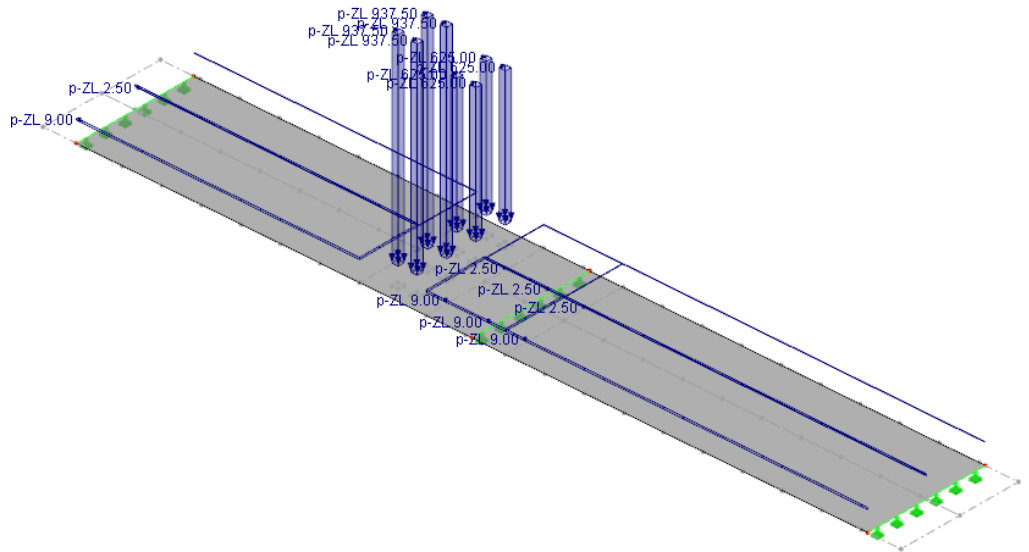

Figure 6.15 Load step 5

We can check the generated loads in table 3.10 Free Polygon Loads.

3.10 Free Polygon Loads

No.	On Surfaces No.	Projection	Load Distribution	Load Direction	Surface base area nodes [m] X1,Y1; X2,Y2; X3,Y3; ...	Corner Points		
						1st Corner Point No.	2nd Corner Point No.	3rd Corner Point No.
1	1.2	XY	Uniform	ZL	20.4000000208616,7.20000000			
2	1.2	XY	Uniform	ZL	20.4000000208616,5.20000000			
3	1.2	XY	Uniform	ZL	19.1999999731779,7.20000000			
4	1.2	XY	Uniform	ZL	19.1999999731779,5.20000000			
5	1.2	XY	Uniform	ZL	-2.09999990463257,8;17.89999			
6	1.2	XY	Uniform	ZL	27.1000003814697,8;50,8;50,4;			
7	1.2	XY	Uniform	ZL	22.1000003814697,8;27.10000			
8	1.2	XY	Uniform	ZL	20.4000000208616,3.20000000			
9	1.2	XY	Uniform	ZL	20.4000000208616,1.20000000			
10	1.2	XY	Uniform	ZL	19.1999999731779,3.20000000			
11	1.2	XY	Uniform	ZL	19.1999999731779,1.20000000			
12	1.2	XY	Uniform	ZL	-2.09999990463257,4;17.89999			
13	1.2	XY	Uniform	ZL	22.1000003814697,4;27.10000			

Figure 6.16 Table 3.10 with generated loads

The basic data of the generated load cases is managed in the *Edit Load Cases and Combinations* dialog box.

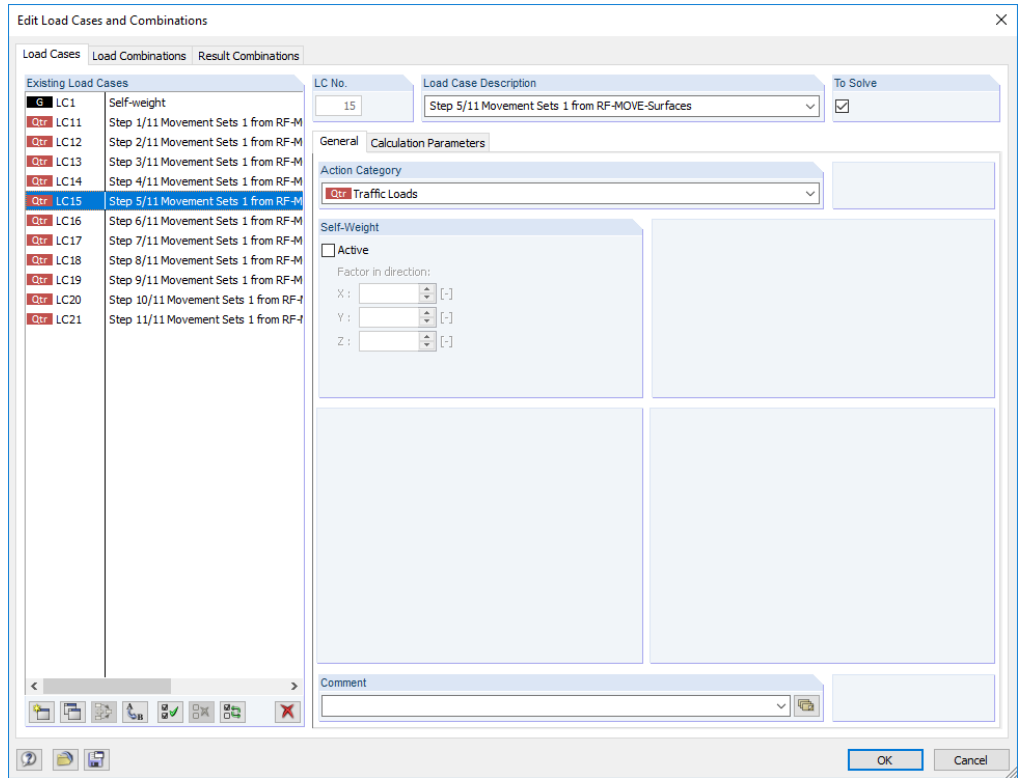

Figure 6.17 Dialog box Edit Load Cases and Combinations

7 Literature



- [1] EN 1991-2 (2003): Eurocode 1: Actions on structures - Part 2: Traffic loads on bridges
[Authority: The European Union Per Regulation 305/2011, Directive 98/34/EC, Directive 2004/18/EC]